

JTM

SUCTION
WATER MANOMETERS

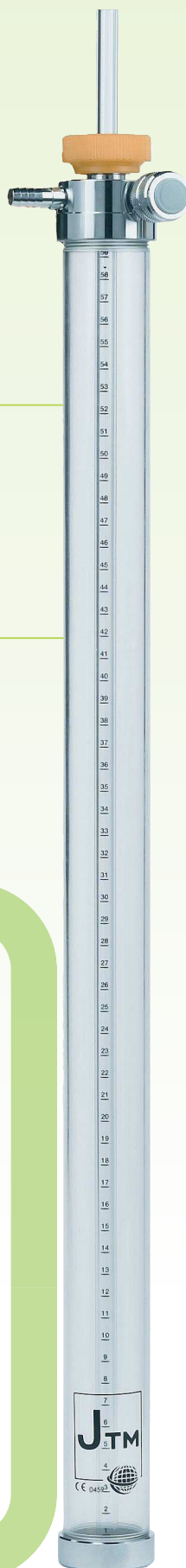

TECHNOLOGIE
MEDICALE



RAIL MOUNTING SYSTEMS

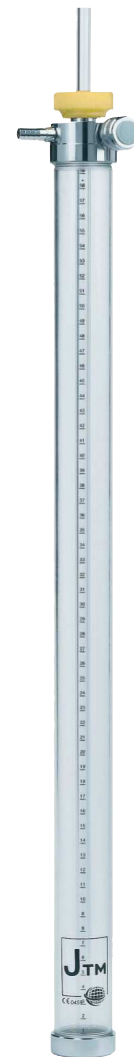

Other standards available upon request.

DIRECT PROBES



AFNOR direct probe



BS direct probe



DIN direct probe



CZECH direct probe

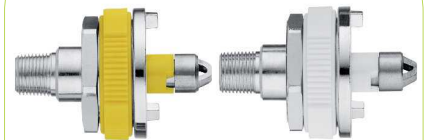

OHMEDA direct probes



NORDIC direct probe



CARBUROS direct probe



DISS direct probe



UNI direct probe



Other standards available upon request.

JTM WATER MANOMETER

The water manometer is used to measure and to adjust a low vacuum level (situated between the atmospheric pressure and 90 mbar). It is mainly used in the context of thoracic or tracheal suction but also in neonatology. The water manometer should be connected to a vacuum source on the wall either using a direct probe or a rail mounting system. It should be associated with a collection jar (equipped with a long plunger tube) and a suction hose.

Main technical features:

Active medical device of class IIa.

In compliance with the EN ISO 10079-3: 2009 standard (former EN 13220: 1998).

- Body and graduated rod made of polycarbonate.
- Head and bottom made of chromium-plated brass.
- Micrometric-incremented knob.
- Rod graduated every cm, ensuring vacuum level reading accuracy.
- Measuring unit: water centimeter (cm H₂O).
- The water manometer offers a very fine adjustment and an ongoing visual control of the vacuum level. The vacuum adjustment is physical rather than mechanical, thereby ensuring great reliability and stability.
- A unit serial number is engraved on the body of each water manometer ensuring its identification and traceability. 8 digits number indicating the manufacturing year and month as well as the unit serial number of the device.

Many versions available:

- Available configurations: Single and Twin.
The single version must be used with two collection jars, including one with a long plunger tube.
The twin version should be used with one collection jar only.
- Available lengths:
 - 60 cm, allowing a vacuum level adjustment up to 55 cm H₂O
 - 100 cm, allowing a vacuum level adjustment up to 90 cm H₂O

- Inlets: 12x100 F – 1/4G M – 1/8NPT F – 3/8G BSP F.
- Available connections to the wall outlet: Direct probe or Rail mounting system.
- Standards: AFNOR (French Standard) - BS (British Standard) - DIN (German Standard) - US OHMEDA DIAMOND (American Standard) - NORDIC (Scandinavian Standard) - UNI (Italian Standard).
- Weight (with direct probe):
 - Single JTM 60 cm: 800 g
 - Single JTM 100 cm: 1000 g
 - Twin JTM 60 cm: 1200 g
 - Twin JTM 100 cm: 1460 g
- Dimensions (with direct probe):

	JTM model	Length	Width
Single	60 cm	70 cm	8 cm
	100 cm	110 cm	8 cm
Twin	60 cm	70 cm	13 cm
	100 cm	110 cm	13 cm

Use, cleaning and maintenance:

Refer to the detailed working explanation hereafter.

Regularly check the complete tightness of the device.

Clean and disinfect the whole device.

If using disinfecting products please check their compatibility with polycarbonate.

The polycarbonate tubes do **not** resist to autoclave up to 134°C.

Cold sterilization or autoclave up to 121°C maximum is recommended.

Do not lay under water.



J01

Single and Twin water manometers, 60 cm.



J02

2L collection jar with moulded hanger, polysulfone, with screw-fit metal lid and long plunger tube. Ref. 15055

HOW DOES THE JTM WATER MANOMETER WORK?

Working mode of the single water manometer

- The JTM barometric water manometer essentially consists of a water tube in which the submerged height of a plunger tube can be adjusted (see drawing).
- The water tube is connected to the primary suction in point "A" (high vacuum source), while the outlet in point "B" is blocked to simulate a suction in closed circuit, the plunger tube being submerged till height in point "H" (as defined by the medical staff) and its upper side remaining out in the open.
- When opening the regulation knob "R" vacuum is created at the upper level of liquid contained in the water tube: the level of the liquid in the plunger tube (in perfect balance with the one of the water tube till this moment) rapidly goes down.
- As soon as the level reaches the bottom part of the plunger tube, air bubbles come out and make the balance with the requested suction level adjusted in point "R".
- The suction in point "B" is then equal to the height in point "H" (in cm H₂O). The barometric water manometer is then ready to function and the light bubbling can be visually controlled. Please note that the inopportune bubbling has a very low influence on the variation of "H".

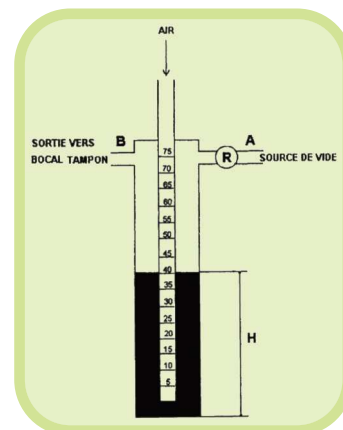

Working mode of the twin water manometer

For any pleural drainage is a set of 3 jars necessary (Fig. 1). The suction must be regular, neither too high nor too low. A filling of air or a variation in pressure during a cough for instance must be absolutely avoided.

The function of the 3 jars (Fig. 1) is the following:

- Jar "A": Limitation of the maximum suction
- Jar "B": Limitation of the minimum suction
- Jar "C": Collection jar used to collect the sucked liquids

The JTM barometric twin water manometer is used to avoid the accumulation of jars on the floor: one sole collection jar is necessary to collect the sucked liquids.

In Fig. 2 the twin water manometer replaces the jars "A" and "B".

The tube "A" replaces the jar "A" as a limiter of maximum suction.

The tube "B" replaces the jar "B" as a limiter of minimum suction.

Instructions for use:

- The tube "A" should be filled in with sterile water up to approximately 10 cm from the upper stopper.
- The plunger stem should be submerged up to a certain height "H" determined by the medical staff: definition of the maximum suction.

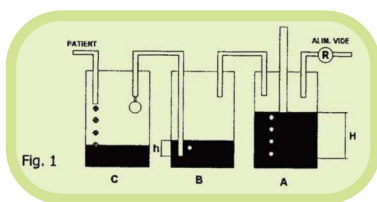

- The tube "B" should be filled in with sterile water up to the requested height to determine the minimum suction.
- The patient outlet must be blocked to adjust the requested maximum suction (simulation of a pleural drainage).

The graduated plunger rod should be submerged up to the height defined by the doctor. The upper part of the plunger stem is out in the open.



Open the regulation knob "R": as soon as it is open the water level goes down rapidly and bubbles appear in water tube "A". The value of the maximum suction is adjusted and can be read on the graduation of the rod. The value of the minimum suction must have been pre-determined in advanced in tube "B" by the height of the water.

Working mode:

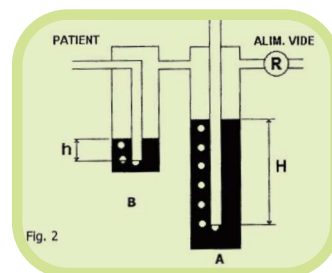

- Once the patient is connected through the collection jar, the pleural cavity communicates with tubes "A" and "B": each time the inter-pleural pressure increases, the air comes out from the lung.
- In case the inter-pleural pressure becomes negative then the water level increases in the submerged stem in tube "B" thus avoiding the air to get into the pleura.







AFNOR French Standard	JTM WATER MANOMETERS			
	Single	Single	Twin	Twin
	60 cm	100 cm	60 cm	100 cm
Inlet thread: 12x100 F	15076	15078	15065	15066
Inlet thread: 1/4G M	15075	15077	15067	15068
Mounted with AFNOR direct probe 	15079	15080	15083	15084
Mounted with AFNOR complete rail mounting system (polycarbonate clamp) 	15081	15082	15107	15106





BS British Standard	JTM WATER MANOMETERS			
	Single	Single	Twin	Twin
	60 cm	100 cm	60 cm	100 cm
Inlet thread: 1/4G M	15075	15077	15067	15068
Mounted with BS direct probe 	15114	15112	15110	15108
Mounted with BS complete rail mounting system (polycarbonate clamp) 	15115	15113	15111	15109

Please contact us for other configurations.



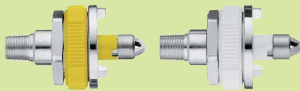

DIN German Standard	JTM WATER MANOMETERS			
	Single	Single	Twin	Twin
	60 cm	100 cm	60 cm	100 cm
Inlet thread: 1/4G M	15075	15077	15067	15068
Mounted with DIN direct probe 	15122	15120	15118	15116
Mounted with DIN complete rail mounting system (polycarbonate clamp) 	15123	15121	15119	15117



US OHMEDA American Standard	JTM WATER MANOMETERS			
	Single	Single	Twin	Twin
	60 cm	100 cm	60 cm	100 cm
ISO colour (yellow)				
US colour (white)				
Inlet thread: 1/4G M	15075	15077	15067	15068
Inlet thread: 1/8NPT F	15073	15074	15063	15064
Mounted with US OHMEDA direct probe 	—	—	—	—
	15138	15136	15134	15132
Mounted with US OHMEDA complete rail mounting system (polycarbonate clamp) 	—	—	—	—
	15139	15137	15135	15133

— Available upon request only.
Please contact us for other configurations.

NORDIC Scandinavian Standard	JTM WATER MANOMETERS			
	Single	Single	Twin	Twin
	60 cm	100 cm	60 cm	100 cm
Inlet thread: 1/8NPT F	15073	15074	15063	15064
Inlet thread: 1/4G M	15075	15077	15067	15068
Mounted with NORDIC direct probe 	15130	15128	15126	15124
Mounted with NORDIC complete rail mounting system (polycarbonate clamp) 	15131	15129	15127	15125

Please contact us for other configurations.

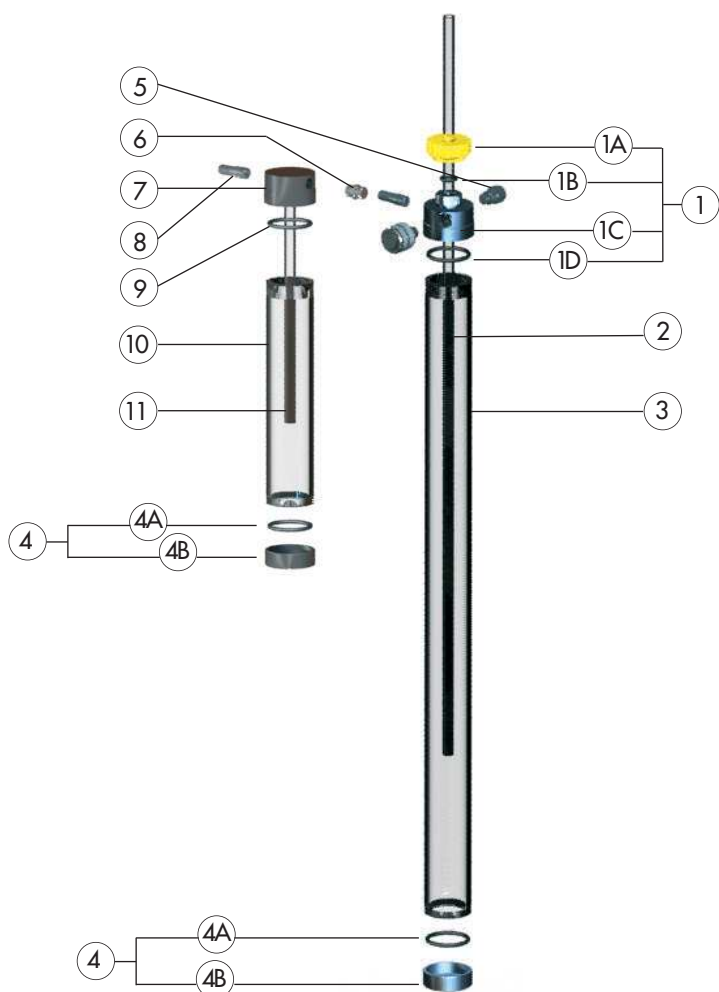

Reference	Description
HEAD	
1	11885 Complete head for single JTM 11892 Complete head for twin JTM
1A	11898 Nut for graduated rod
1B	11781 1/2G gasket for graduated rod
1C	11887 Complete regulation knob
1D	11567 Gasket for JTM head
GRADUATED ROD	
2	11879 60 cm stem 11880 100 cm stem
BODY	
3	11881 60 cm complete body 11882 100 cm complete body
BOTTOM	
4	11884 Complete JTM bottom with gasket
4A	11567 Gasket for JTM bottom
4B	11886 JTM bottom only
5	11174 Inlet adaptor 12x100 F 11178 Inlet adaptor 1/4G M 11176 Inlet adaptor 1/8NPT F 16922 Inlet adaptor 3/8G BSP F
6	16985 Connector 1/8G M
7	11896 Limiter head only for twin JTM
8	11889 Suction tubing nipple 1/8G M
9	11567 Gasket
10	11894 Limiter body only for twin JTM
11	11895 Limiter stem only for twin JTM



Also Available

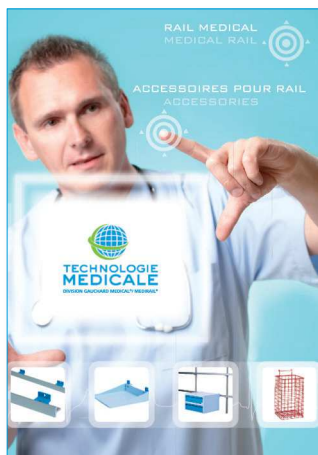

Distributed by

SUCTION
WATER MANOMETERS



TECHNOLOGIE
MEDICALE

101, rue Vaillant Couturier B.P. 46 F-93136 NOISY-LE-SEC CEDEX France
 Tel: 33 (0)1 48 45 58 95 - Fax: 33 (0)1 49 42 90 21 - 33 (0)1 48 45 29 00 - info@technologiemedicale.com
 www.technologiemedicale.com